

## Chain hoists (HSZ-C Series)



### Features:

- Safety load brake
- Minimal maintenance.
- Lightweight and compact.
- Minimal operational load.
- Hand chain wheel cover and brake cover protects inner gears.
- All hoists tested with 1.5 times the rated capacity. (10 Tons - 1.25 times )
- Chain end anchor prevents chain slip when full chain length is utilized.
- Safety latches on all hooks.



### Application:

- Versatile lifting of heavy loads with manual effort where electrical fitting is not feasible
- Easily attached to a trolley, can be used as a traveling chain block
- Suitable for overhead conveying systems, hand traveling crane and jib crane.



0.5T

1T

1.5T

2T

3T

5T



0.5, 1, 1.5, 2T

3, 5T

**Chain hoists (HSZ-C Series)**

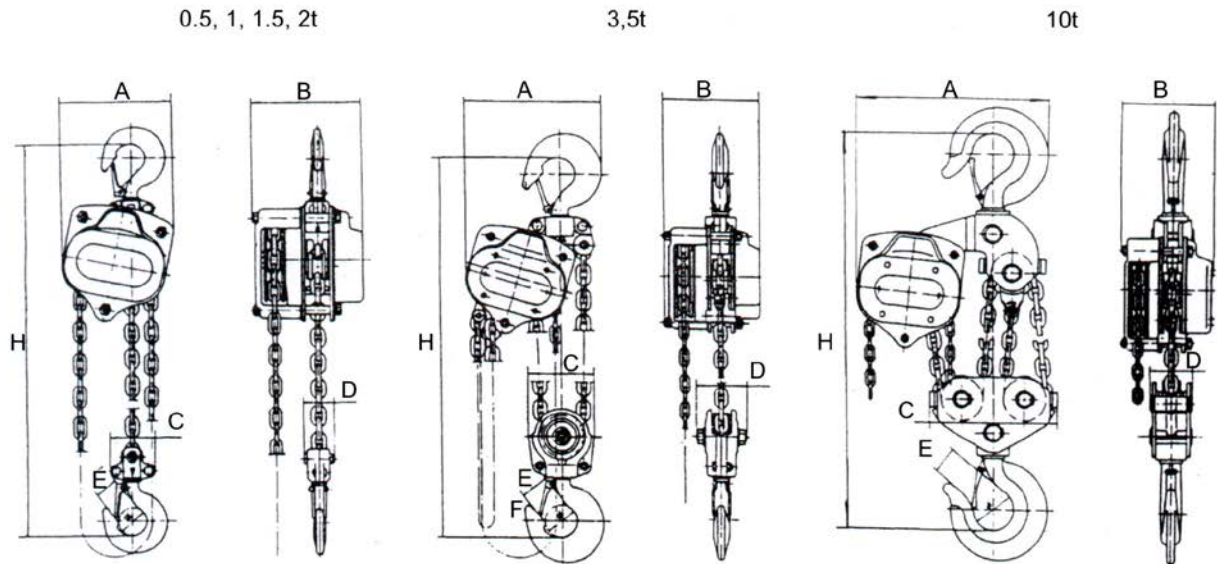

Model	HSZ-C0.5	HSZ-C1	HSZ-C1.5	HSZ-C2	HSZ-C3	HSZ-C5	HSZ-C10	
Capacity /Ton	0.5	1.0	1.5	2.0	3.0	5.0	10.0	
Lift height /m	2.5	2.5	2.5	3	3	3	3	
Test load /Ton	0.75	1.50	2.25	3.00	4.50	7.50	12.50	
Headroom (H <sub>min</sub> ) /mm	312	360	385	430	490	675	880	
Operating effort /kg	27.0	31.5	36.0	40.0	47.5	48.0	49.5	
Specification of load chain /mm	5 X 15	6 X 18	7.1 X 21	8 X 24	7.1 X 21	9 X 27	9 X 27	
No. of load chain fall lines	1	1	1	1	2	2	4	
Specification of hand chain /mm	5X22	5X22	5X22	5.5X23.5	5X22	5.5X23.5	5.5X23.5	
Dimensions (mm)	A	140	156	176	223	223	252	380
	B	131	151	151	183	151	183	183
	C	60	61	60	67	106	133	263
	D	33	31	44	58	85	64	88
	E	31	33	38	40	44	49	64
	F /Ø	36	39	43	45	52	58	85
Packing size /cm	22X17X23	24X18X23	26X18X26	32X20X29	31X18X33	40X20X36	54X50X31	
Net weight /kg	8.2	11.3	13.2	21.3	21.7	29.7	66.0	